



ATAR course examination, 2020

Question/Answer booklet

CHEMISTRY

Place one of your candidate identification labels in this box.
Ensure the label is straight and within the lines of this box.

WA student number: In figures

--	--	--	--	--	--	--	--	--

In words

Time allowed for this paper

Reading time before commencing work: ten minutes
Working time: three hours

Number of additional
answer booklets used
(if applicable):

Materials required/recommended for this paper

To be provided by the supervisor

This Question/Answer booklet
Multiple-choice answer sheet
Chemistry Data booklet

To be provided by the candidate

Standard items: pens (blue/black preferred), pencils (including coloured), sharpener, correction fluid/tape, eraser, ruler, highlighters

Special items: up to three calculators, which do not have the capacity to create or store programmes or text, are permitted in this ATAR course examination

Important note to candidates

No other items may be taken into the examination room. It is **your** responsibility to ensure that you do not have any unauthorised material. If you have any unauthorised material with you, hand it to the supervisor **before** reading any further.

Copyright © School Curriculum and Standards Authority 2020

Ref: 20-011



CHE

Structure of this paper

Section	Number of questions available	Number of questions to be answered	Suggested working time (minutes)	Marks available	Percentage of examination
Section One Multiple-choice	25	25	50	25	25
Section Two Short answer	9	9	60	76	35
Section Three Extended answer	6	6	70	88	40
				Total	100

Instructions to candidates

1. The rules for the conduct of the Western Australian external examinations are detailed in the *Year 12 Information Handbook 2020: Part II Examinations*. Sitting this examination implies that you agree to abide by these rules.
2. Write your answers in this Question/Answer booklet preferably using a blue/black pen. Do not use erasable or gel pens.
3. Answer the questions according to the following instructions.

Section One: Answer all questions on the separate Multiple-choice answer sheet provided. For each question, shade the box to indicate your answer. Use only a blue or black pen to shade the boxes. Do not use erasable or gel pens. If you make a mistake, place a cross through that square, then shade your new answer. Do not erase or use correction fluid/tape. Marks will not be deducted for incorrect answers. No marks will be given if more than one answer is completed for any question.

Sections Two and Three: Write your answers in this Question/Answer booklet.

4. When calculating numerical answers, show your working or reasoning clearly. Your working should be in sufficient detail to allow your answers to be checked readily and for marks to be awarded for reasoning. Express numerical answers to the appropriate number of significant figures and include appropriate units where applicable.
5. You must be careful to confine your answers to the specific questions asked and to follow any instructions that are specific to a particular question.
6. Supplementary pages for planning/continuing your answers to questions are provided at the end of this Question/Answer booklet. If you use these pages to continue an answer, indicate at the original answer where the answer is continued, i.e. give the page number.
7. The Chemistry Data booklet is not to be handed in with your Question/Answer booklet.

See next page

Section One: Multiple-choice

25% (25 Marks)

This section has **25** questions. Answer **all** questions on the separate Multiple-choice answer sheet provided. For each question, shade the box to indicate your answer. Use only a blue or black pen to shade the boxes. Do not use erasable or gel pens. If you make a mistake, place a cross through that square, then shade your new answer. Do not erase or use correction fluid/tape. Marks will not be deducted for incorrect answers. No marks will be given if more than one answer is completed for any question.

Suggested working time: 50 minutes.

1. Holmium (Ho) reacts quickly with hot water to form holmium hydroxide and hydrogen:

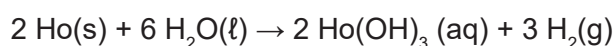

The oxidising and reducing agents in this equation are

	Oxidising agent	Reducing agent
(a)	H ₂ O	H ₂
(b)	Ho	H ₂ O
(c)	H ₂ O	Ho
(d)	Ho(OH) ₃	Ho

2. Which of the following classifies the given acids as monoprotic or polyprotic?

	Monoprotic	Polyprotic
(a)	HCl	CH ₃ COOH
(b)	CH ₃ CH ₂ COOH	H ₂ SO ₄
(c)	CH ₃ COOH	CH ₃ CH ₂ COOH
(d)	H ₂ SO ₄	HCl

3. Oxidation-reduction reactions involve the transfer of

- (a) protons.
- (b) electrons.
- (c) hydroxide ions.
- (d) hydrogen ions.

4. The number of possible isomers of C₂H₂F₂ is

- (a) 1
- (b) 2
- (c) 3
- (d) 4

See next page

5. Which of the following statements about pure water are correct?
- (i) Pure water is a weak electrolyte that undergoes self-ionisation.
 - (ii) The equilibrium constant for the ionisation of pure water at 25 °C is 1.00×10^{-14} .
 - (iii) Pure water ionises completely at 25 °C, hence $[H^+] = [OH^-]$.
 - (iv) The ionisation of pure water produces twice as many hydrogen ions as hydroxide ions.
- (a) i and ii only
 - (b) ii and iii only
 - (c) iii and iv only
 - (d) i, ii, iii and iv
6. What type of redox reaction occurs in a galvanic cell and what is one possible use for such a cell?

	Type of redox reaction	Possible use of a galvanic cell
(a)	non-spontaneous	the plating of cheap metallic objects with precious metals
(b)	spontaneous	the plating of cheap metallic objects with precious metals
(c)	non-spontaneous	the production of an electric current for a torch
(d)	spontaneous	the production of an electric current for a torch

7. The following equation shows the reaction between copper and concentrated nitric acid:

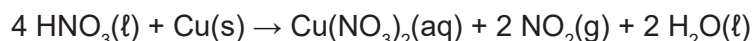

Observable changes associated with this reaction are the dissolving of the copper, the formation of a deep blue solution and the evolution of a pungent brown gas.

Which of the following are some of the atomic/molecular scale events needed for these observable changes to occur?

- (i) collisions between HNO_3 molecules and Cu atoms
 - (ii) donation and acceptance of protons
 - (iii) reduction of copper atoms
- (a) i only
 - (b) ii only
 - (c) i and iii only
 - (d) i, ii and iii

8. Energy profile diagrams for two different chemical reactions (A and B) are shown below.

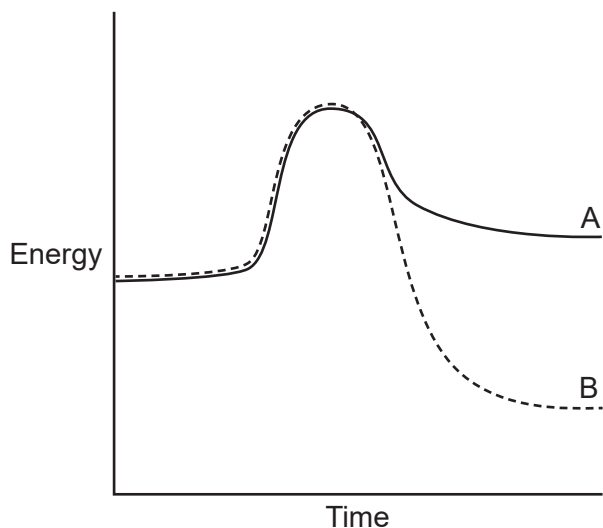

Which of these reactions is the more likely to be reversible and why?

- (a) Reaction A, because its forward reaction is endothermic.
 (b) Reaction B, because its forward reaction is exothermic.
 (c) Reaction A, because the activation energy of its reverse reaction is smaller than that for Reaction B.
 (d) Neither, because the activation energies of their forward reactions are the same.
9. Consider the molecule shown below.

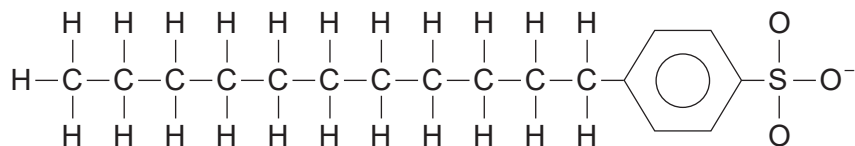

This molecule shows

- (a) an anionic detergent which contains a sulfonate group.
 (b) a monomer that can be used to synthesise a condensation polymer.
 (c) a carboxylic acid which can be used to synthesise a soap.
 (d) an aromatic hydrocarbon which has donated an electron.

10. Which of these statements regarding organic molecules are correct?

- (i) Organic molecules have hydrocarbon skeletons.
- (ii) Functional groups consist of groups of atoms or a particular type of bond.
- (iii) Functional groups influence the chemical properties of organic molecules.
- (iv) Functional groups influence the physical properties of organic molecules.

- (a) i and iii only
- (b) ii and iv only
- (c) i, ii and iii only
- (d) i, ii, iii and iv

11. Which of the following pairs of molecules can form peptide bonds with each other?

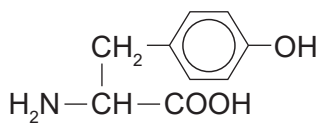
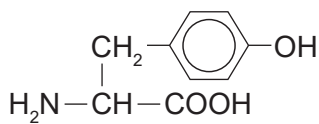
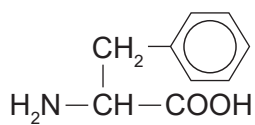
(i)	$\begin{array}{cccc} \text{H} & \text{H} & \text{H} & \text{H} \\ & & & \\ \text{HO}-\text{C} & -\text{C} & -\text{C} & -\text{C}-\text{OH} \\ & & & \\ \text{H} & \text{H} & \text{H} & \text{H} \end{array}$ <p>butan-1,4-diol</p>	$\begin{array}{cccc} \text{H} & \text{H} & \text{H} & \text{H} \\ & & & \\ \text{H}_2\text{N}-\text{C} & -\text{C} & -\text{C} & -\text{C}-\text{NH}_2 \\ & & & \\ \text{H} & \text{H} & \text{H} & \text{H} \end{array}$ <p>butan-1,4-diamine</p>
(ii)	 <p>tyrosine</p>	 <p>tyrosine</p>
(iii)	$\begin{array}{ccc} \text{CH}_3 & -\text{CH} & -\text{CH}_3 \\ & & \\ \text{H}_2\text{N} & -\text{CH} & -\text{COOH} \end{array}$ <p>valine</p>	 <p>phenylalanine</p>
(iv)	$\begin{array}{ccc} \text{H} & \text{H} & \\ & & \\ \text{H}-\text{C} & -\text{C} & -\text{O}-\text{H} \\ & & \\ \text{H} & \text{H} & \end{array}$ <p>ethanol</p>	$\begin{array}{ccc} \text{H} & \text{H} & \text{O} \\ & & // \\ \text{H}-\text{C} & -\text{C} & -\text{C} \\ & & \backslash \\ \text{H} & \text{H} & \text{O}-\text{H} \end{array}$ <p>butanoic acid</p>

- (a) i and iv only
- (b) ii and iii only
- (c) i, ii and iii only
- (d) i, ii, iii and iv

12. A group of Chemistry students observed a demonstration in which solid sodium chloride was added to an aqueous solution of copper(II) chloride in a glass reaction vessel. A tightly-fitting lid was placed on the reaction vessel. The solid sodium chloride was allowed to dissolve and then the entire system was heated and then cooled. This resulted in colour changes. The reaction system is shown below.

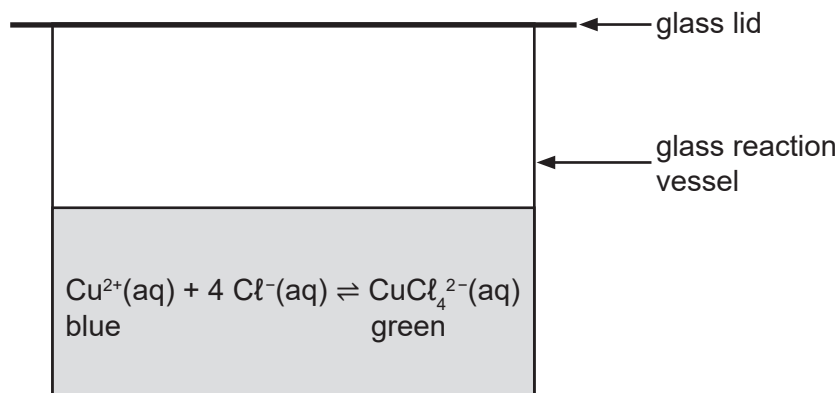

The students were asked to decide if the system was open or closed and if the demonstration involved chemical and/or physical processes. Their responses are shown in the following table.

Which student has the correct responses?

	Student	Type of system (open/closed)	Type of process (chemical/physical)
(a)	1	closed	physical
(b)	2	closed	chemical
(c)	3	closed	chemical and physical
(d)	4	open	chemical

13. Which of the following alcohols would you expect to have the highest boiling point?

- (a) pentan-1-ol
- (b) pentan-2-ol
- (c) pentan-3-ol
- (d) 2-methylbutan-2-ol

14. The Protein Data Bank contains information relating to the structures of proteins. The structure of a protein is important because it is related closely to its

- (a) equilibrium constant.
- (b) bonding capacity.
- (c) nutritional value.
- (d) function.

See next page

15. The reaction of aniline ($\text{C}_6\text{H}_5\text{NH}_2$) with water is an equilibrium process:

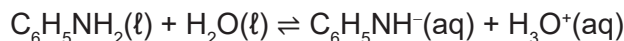

A conjugate acid-base pair in this process is

- (a) $\text{C}_6\text{H}_5\text{NH}^-$ and H_2O
 (b) $\text{C}_6\text{H}_5\text{NH}_2$ and $\text{C}_6\text{H}_5\text{NH}^-$
 (c) $\text{C}_6\text{H}_5\text{NH}^-$ and H_3O^+
 (d) H_3O^+ and $\text{C}_6\text{H}_5\text{NH}_2$
16. Which of the following is **not** a characteristic of a system in dynamic equilibrium?
- (a) The mass of the reactants equals the mass of the products.
 (b) Reactants are forming products and products are forming reactants.
 (c) The rates of the forward and reverse reactions are equal.
 (d) The position of the equilibrium is affected by temperature.
17. Acid-base indicators
- (a) are oxidising or reducing agents.
 (b) change colour at a specific pH value.
 (c) are strong acids or bases.
 (d) are weak acids or bases.
18. A chemist prepares solutions of nitrous acid and hydrocyanic acid that have the same concentration.

The K_a values of these acids are:

- nitrous acid (HNO_2) is 4.6×10^{-4}
- hydrocyanic acid (HCN) is 6.17×10^{-10} .

Which of these two acids is the stronger and which has the higher pH?

	Stronger acid	Higher pH
(a)	nitrous acid	nitrous acid
(b)	nitrous acid	hydrocyanic acid
(c)	hydrocyanic acid	hydrocyanic acid
(d)	hydrocyanic acid	nitrous acid

19. The following half-equations show some predicted standard reduction potentials for seaborgium (Sg) oxides:

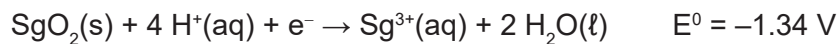
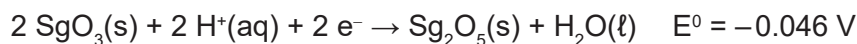

The strongest reducing agent is

- (a) SgO_3
 (b) Sg_2O_5
 (c) SgO_2
 (d) Sg^{3+}
20. Impure copper must be purified before it is used in applications where very high electrical conductivity is required. The purification of copper, which is also known as electrorefining, can be performed in an electrochemical cell similar to the one shown below.

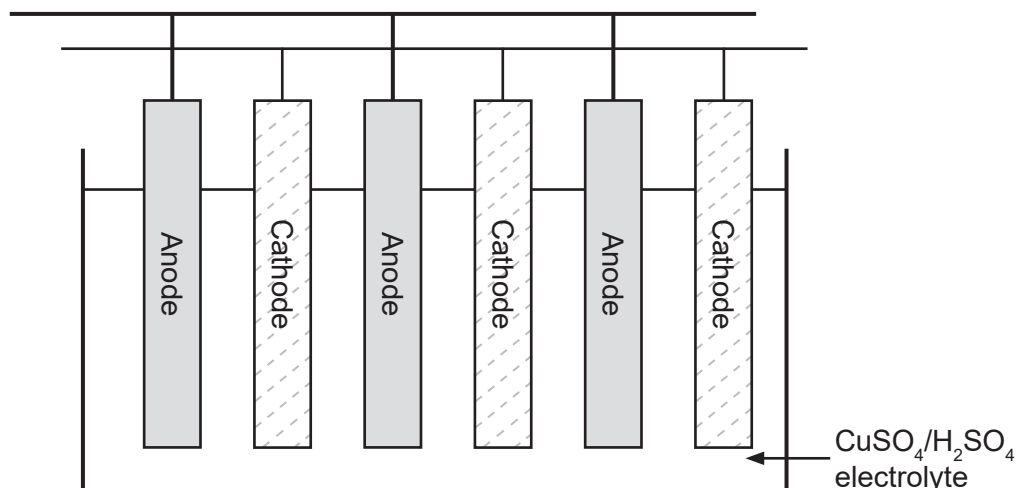

Which statement regarding this electrochemical cell is correct?

- (a) This cell requires the application of an external electrical potential difference for it to function.
 (b) During operation, the electrolyte becomes less blue because the concentration of Cu^{2+} ions in the electrolyte decreases.
 (c) This cell will not work because it does not have a salt bridge.
 (d) The impure copper is cast as cathodes.

See next page

21. Polyacrylonitrile fibres can be used to make blankets and carpets. The structural formula of a segment of this polymer is shown below.

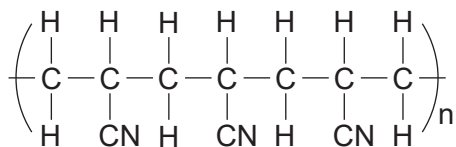

The structural formula of the monomer used to make polyacrylonitrile is:

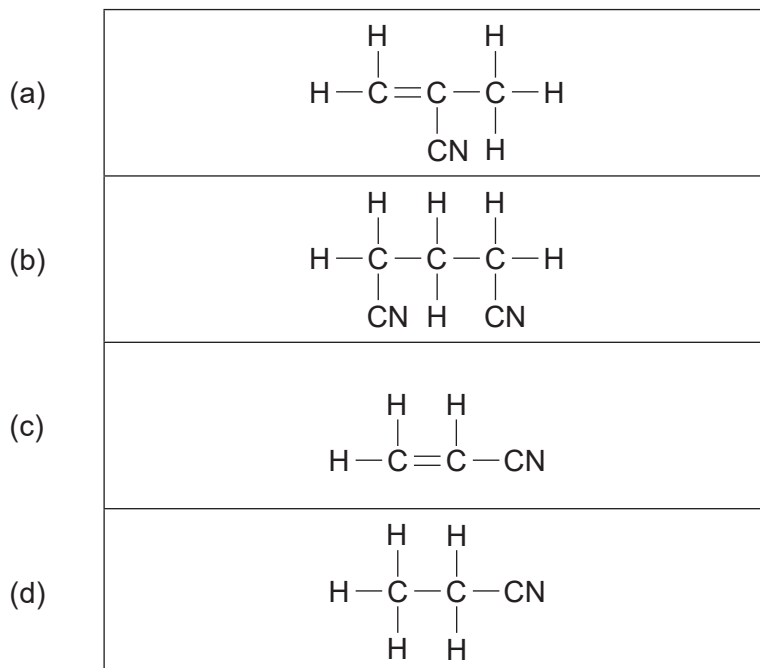

22. When cleaning greasy/dirty objects in hard water, it is **best** to use
- a soap, because it forms a precipitate with the ions causing water hardness, thereby removing these ions from solution.
 - a detergent, because it does not react with the ions causing water hardness.
 - a detergent, because it forms a precipitate with the ions causing water hardness, thereby removing these ions from solution.
 - a soap, because it does not react with the ions causing water hardness.

23. Which of the following diagrams represents the micelle that forms in water when soap is used to remove grease from dirty dishes?

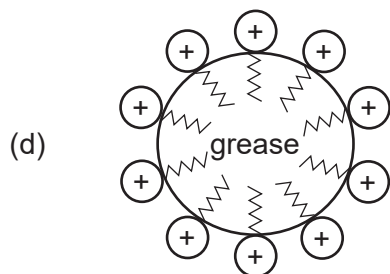
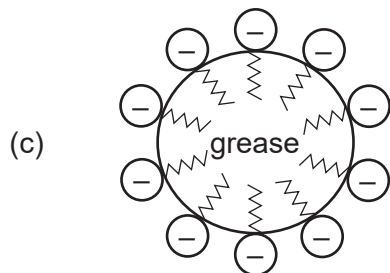
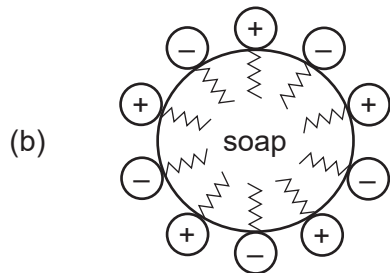
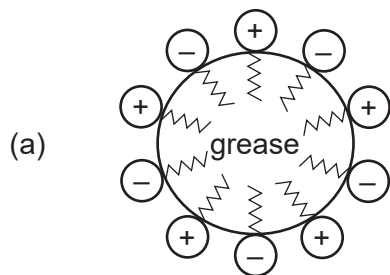

DO NOT WRITE IN THIS AREA AS IT WILL BE CUT OFF

24. Consider the following equilibrium:

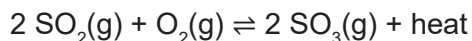

A mixture of these gases was at equilibrium in a sealed container with a movable piston, as shown below.

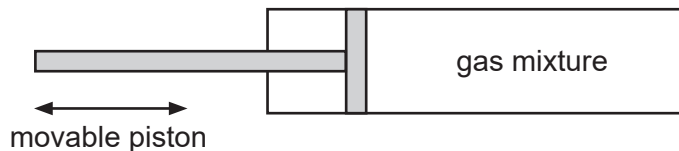

A change was applied to the system at T1 and the results of this change are shown in the following graph.

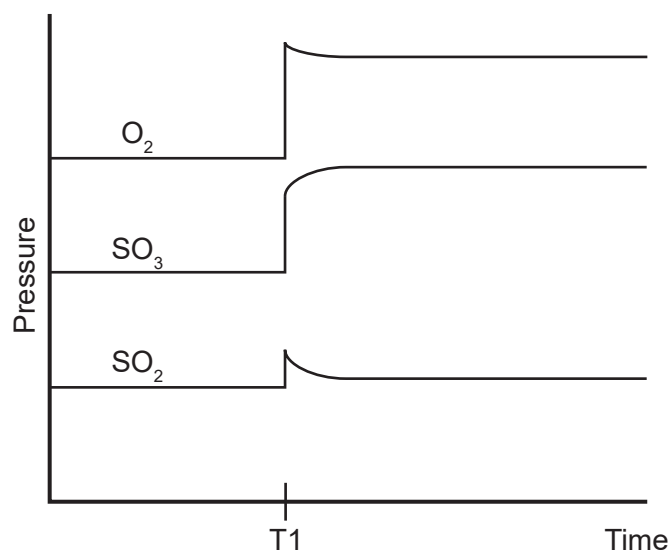

What was the change that occurred at T1?

- (a) An inert gas was added to the reaction vessel.
 (b) The reaction vessel was heated.
 (c) A catalyst was added to the reaction vessel.
 (d) The volume of the reaction vessel was decreased.
25. A chemist performed an acid-base titration. The acid was in a burette and a pipette was used to deliver a known quantity of the base into a conical flask. Which of the following gives the final rinse solution for each of these pieces of equipment?

Final rinse solution		
Burette	Pipette	Conical flask
(a) acid	water	base
(b) acid	base	water
(c) water	base	water
(d) water	water	base

End of Section One

See next page

Section Two: Short answer

35% (76 Marks)

This section has **nine** questions. Answer **all** questions. Write your answers in the spaces provided.

Supplementary pages for planning/continuing your answers to questions are provided at the end of this Question/Answer booklet. If you use these pages to continue an answer, indicate at the original answer where the answer is continued, i.e. give the page number.

Suggested working time: 60 minutes.

Question 26

(4 marks)

Complete this table by giving the IUPAC name or full structural formula of the indicated organic compounds. All hydrogen atoms must be shown.

Full structural formula	IUPAC name
$ \begin{array}{ccccccc} & \text{H} & \text{H} & \text{H} & \text{H} & & \text{H} \\ & & & & & & / \\ \text{H} & - \text{C} & - \text{C} & - \text{C} & - \text{C} & - \text{C} & - \text{N} \\ & & & & & & \backslash \\ & \text{H} & \text{H} & \text{H} & \text{H} & \text{O} & \text{H} \end{array} $	
$ \begin{array}{ccc} \text{H}_3\text{C} & & \text{CH}_3 \\ & \diagdown & / \\ & \text{C} = \text{C} & \\ & / & \diagdown \\ \text{H}_3\text{C} & & \text{CH}_3 \end{array} $	
	heptan-2-amine
	hexan-3-one

See next page

Question 27

(8 marks)

Write balanced equations for any reactions occurring between the following substances and describe the observation(s).

If there is no reaction, write 'no reaction' for the equation and if there is no change observed, write 'no visible reaction' for the observations. Where applicable, use the colours stated in the Chemistry Data Booklet.

Iron filings and dilute hydrochloric acid

Equation
Observation(s)

Chromium(III) nitrate solution and magnesium ribbon

Equation
Observation(s)

Potassium chloride solution and bromine water

Equation
Observation(s)

See next page

DO NOT WRITE IN THIS AREA AS IT WILL BE CUT OFF

Question 28

(5 marks)

Poly(ethylene adipate) is an inexpensive, biodegradable polymer. It is formed when ethylene glycol and adipic acid react. The structural formulae of these two monomers are shown below.

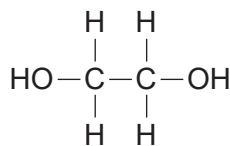

ethylene glycol

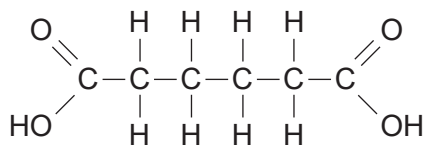

adipic acid

- (a) Draw the structural formula of poly(ethylene adipate). Show two repeating units. (2 marks)

- (b) Classify poly(ethylene adipate) according to the:
- (i) functional group or groups present in its structure. (1 mark)
- _____
- (ii) type of reaction resulting in its formation. (1 mark)
- _____
- (c) Identify a different type of reaction that results in the formation of a polymer. (1 mark)
- _____

The temperature inside the reaction vessel was increased. The heating process was stopped every so often and, once equilibrium had been established at the attained temperature, the amount of hydrogen present in the system was measured. The results are shown on the following graph.

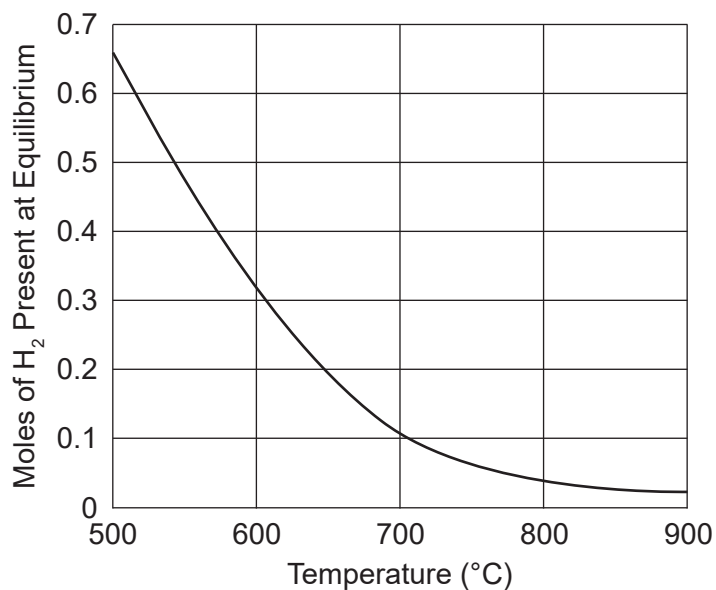

- (c) Using the graph and your answer to part (a), predict the effect of an increase in temperature on the numerical value of K . Justify your prediction. (4 marks)

Question 30

(7 marks)

Sulfur dioxide must be removed from waste industrial gases before they are released into the atmosphere. One method of doing this is the electrolytic conversion of sulfur dioxide into dithionate ($\text{S}_2\text{O}_6^{2-}$):



- (a) Identify the atom that is oxidised and the atom that is reduced in this reaction. (2 marks)

Atom that is oxidised	
Atom that is reduced	

An electrolytic cell, similar to the simplified one shown below, can be used for the above process.

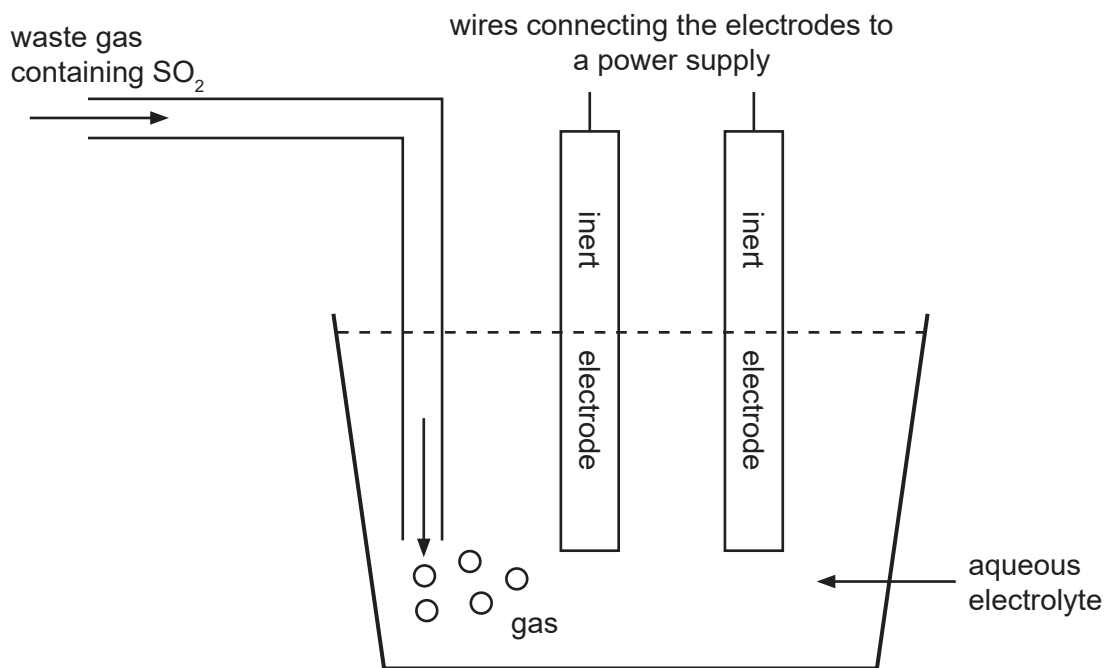

A chemist, who was investigating this process, used 1.00 mol L⁻¹ sodium perchlorate (NaClO_4) solution as the electrolyte. The chemist found that the pH of this electrolyte steadily decreased as more SO_2 -containing waste gas was treated. The final pH was 2.42.

The observed pH change prompted the chemist to change the electrolyte to a mixture of potassium hydrogen phosphate (K_2HPO_4) and potassium dihydrogenphosphate (KH_2PO_4), in which the following equilibrium occurred:

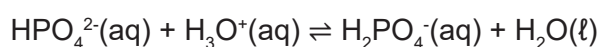

No significant pH changes occurred when this new electrolyte was used.

See next page

Question 31

(9 marks)

The amount of carbon dioxide in the Earth's atmosphere is increasing, leading to more carbon dioxide dissolving in the oceans and hence ocean acidification.

- (a) Complete the following sequence of equations to show what happens to carbon dioxide when it dissolves in water. (3 marks)

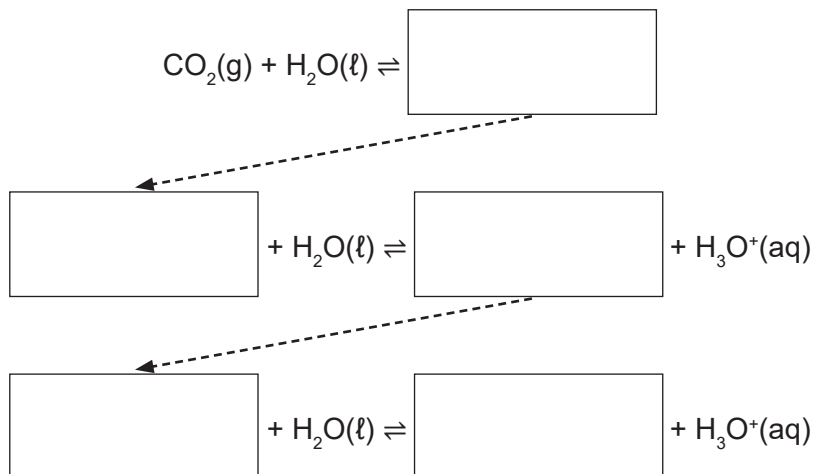

- (b) Other than death, state **two** consequences of the above sequence of equations on marine organisms with shells. (2 marks)

One: _____

Two: _____

- (c) Use Le Châtelier's Principle and the sequence of equations in part (a) to predict what might happen, in relation to ocean acidification, if the United Nations Kyoto Protocol is discarded. Explain your reasoning. (4 marks)

DO NOT WRITE IN THIS AREA AS IT WILL BE CUT OFF

Question 32

(13 marks)

Some students were asked to identify the 'best' cleaning solvent for the removal of graffiti from concrete. They were given black spray paint and five different cleaning solvents.

The students sprayed five different 10 cm by 10 cm areas of a concrete wall with the black paint and allowed the paint to dry for 24 hours. They then used 100 mL of cleaning solvent to try to remove the black paint, with a different cleaning solvent being used for each square. The students subsequently ranked the cleaning solvents from 1 to 5 based on their ability to dissolve the black paint with 1 being the best and 5 being the worst.

The results of the students' investigation, plus some information about the composition of each cleaning solvent, are shown in the table below.

Solvent	Investigation ranking	Composition of cleaning solvent
distilled water	5	water
turpentine	2	straight-chain hydrocarbons containing ten carbon atoms and one double bond
acetone	3	propanone
white spirit	1	straight-chain hydrocarbons C7 to C12
methylated spirits	4	5% methanol, 95% ethanol

- (a) Identify the independent and dependent variables in the students' investigation. (2 marks)

Independent variable	
Dependent variable	

- (b) State **two** variables that the students needed to control in their investigation. (2 marks)

One: _____

Two: _____

See next page

(c) What could the students do to ensure that their investigation was:

(i) valid? (1 mark)

(ii) reliable? (1 mark)

(d) Identify **two** safety risks associated with the students' investigation and state how each risk could be minimised. (4 marks)

Safety risk	How to minimise the risk

(e) Paints contain, among other things, a pigment (which is the paint colour) and a solvent (which dissolves the pigment). When paint dries, the solvent evaporates, leaving the pigment behind.

Use this information, the students' results and your knowledge of chemistry to identify the predominant type of intermolecular force occurring between the pigment molecules in the black paint used by the students. Explain your reasoning. (3 marks)

See next page

Question 33

(9 marks)

A chemist wanted to add a fruity fragrance to an air freshener that he was developing. A colleague suggested the compound ethyl pentanoate which has an apple-like fragrance. The structure for ethyl pentanoate is shown below.

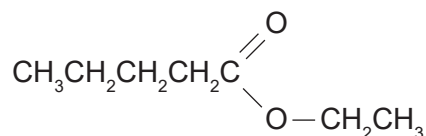

The chemist wanted to check the fragrance of this compound to make sure that it was suitable but there was no ethyl pentanoate in the chemist's laboratory. The only organic substances that the chemist had were a:

- commercial gas cylinder containing ethene
- bottle of pentan-2-one
- bottle of pentan-1-ol
- bottle of pentanal.

Ethyl pentanoate can be synthesised from one or more of the organic substances in the above list in **three** steps.

Describe the steps that will allow the chemist to synthesise ethyl pentanoate. Include balanced equations for all reactions that occur, using molecular formulae for organic compounds. Any inorganic compounds deemed necessary can be used in the procedure. It is not necessary to specify how the products of a particular reaction will be isolated before use in another reaction.

Step One: _____

See next page

Step Two: _____

Step Three: _____

DO NOT WRITE IN THIS AREA AS IT WILL BE CUT OFF

Question 34

(10 marks)

The Haber process is used to make ammonia. The balanced equation for the process is:

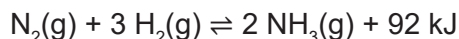

The Haber process provides challenges for industrial operators in relation to the rate of ammonia production and the ammonia yield. This is reflected in the following quotation taken from *Chemistry and Engineering News*:

For copyright reasons this text cannot be reproduced in the online version of this document, but may be viewed at the link listed on the acknowledgements page.

- (a) State whether you agree with the claims about the effects of temperature on the yield of ammonia. Justify your statement using Le Châtelier's Principle. (4 marks)

- (b) State whether you agree with the claims about the effects of temperature on the rate of the Haber process. Justify your statement using collision theory. (6 marks)

End of Section Two
See next page

DO NOT WRITE IN THIS AREA AS IT WILL BE CUT OFF

Section Three: Extended answer

40% (88 Marks)

This section contains **six** questions. You must answer **all** questions. Write your answers in the spaces provided.

Where questions require an explanation and/or description, marks are awarded for the relevant chemical content and also for coherence and clarity of expression. Lists or dot points are unlikely to gain full marks.

Final answers to calculations should be expressed to the appropriate number of significant figures and include appropriate units where applicable.

Supplementary pages for planning/continuing your answers to questions are provided at the end of this Question/Answer booklet. If you use these pages to continue an answer, indicate at the original answer where the answer is continued, i.e. give the page number.

Suggested working time: 70 minutes.

Question 35

(11 marks)

Cytochrome C is a protein found in the cells of many organisms. A biochemist analysed the Cytochrome C from a human and a grey whale to establish their respective α -amino acid sequences.

- (a) What protein structure level does the α -amino acid sequence represent? (1 mark)

The structural formula of a small segment of human Cytochrome C, as written by the biochemist in her notebook, is shown below.

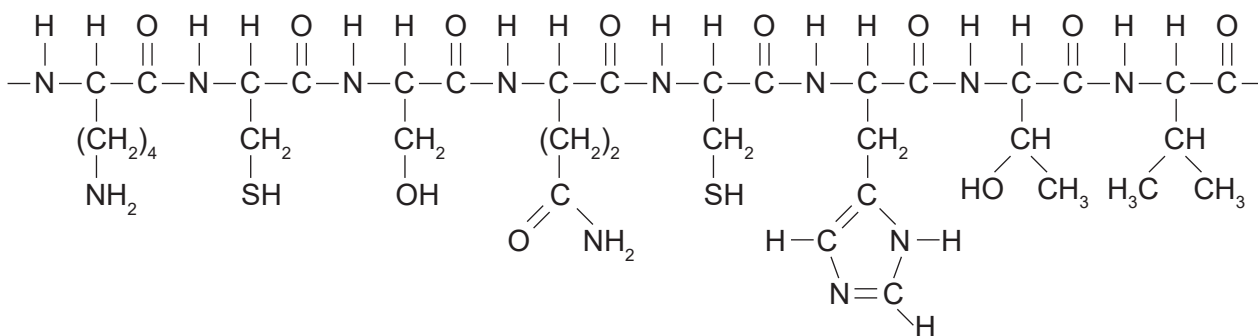

The biochemist wrote the sequence of α -amino acids in the corresponding grey whale Cytochrome C segment in an abbreviated form:

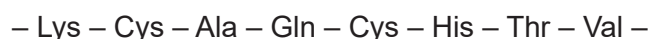

See next page

Question 35 (continued)

- (b) Identify **one** similarity and **one** difference between the given α -amino acid sequences of human and grey whale Cytochrome C. (2 marks)

Similarity: _____

Difference: _____

The biochemist examined the overall three-dimensional folded shape of grey whale Cytochrome C. The biochemist did this by identifying the predominant types of interactions occurring between the side chains of α -amino acids located near each other in grey whale Cytochrome C. Three of the α -amino acid pairs considered by the biochemist are shown in the following table.

- (c) Complete the following table by identifying the predominant side chain interaction for each α -amino acid pair. (3 marks)

α -Amino acid pairs	Predominant side chain interaction
Ala and Val	
Gln and His	
Cys and Cys	

- (d) The biochemist found that both human and grey whale Cytochrome C contain several alpha helices but no beta-pleated sheets. What protein structure level do alpha helices and beta-pleated sheets represent? (1 mark)

Further analysis of human Cytochrome C showed that there was a segment where two other α -amino acids (phenylalanine and leucine) were adjacent to each other. The biochemist obtained pure samples of each of these amino acids and set up an experiment to facilitate their reaction with each other.

- (e) Write a balanced equation, using condensed structural formulae, for a reaction that occurs between phenylalanine and leucine. (2 marks)

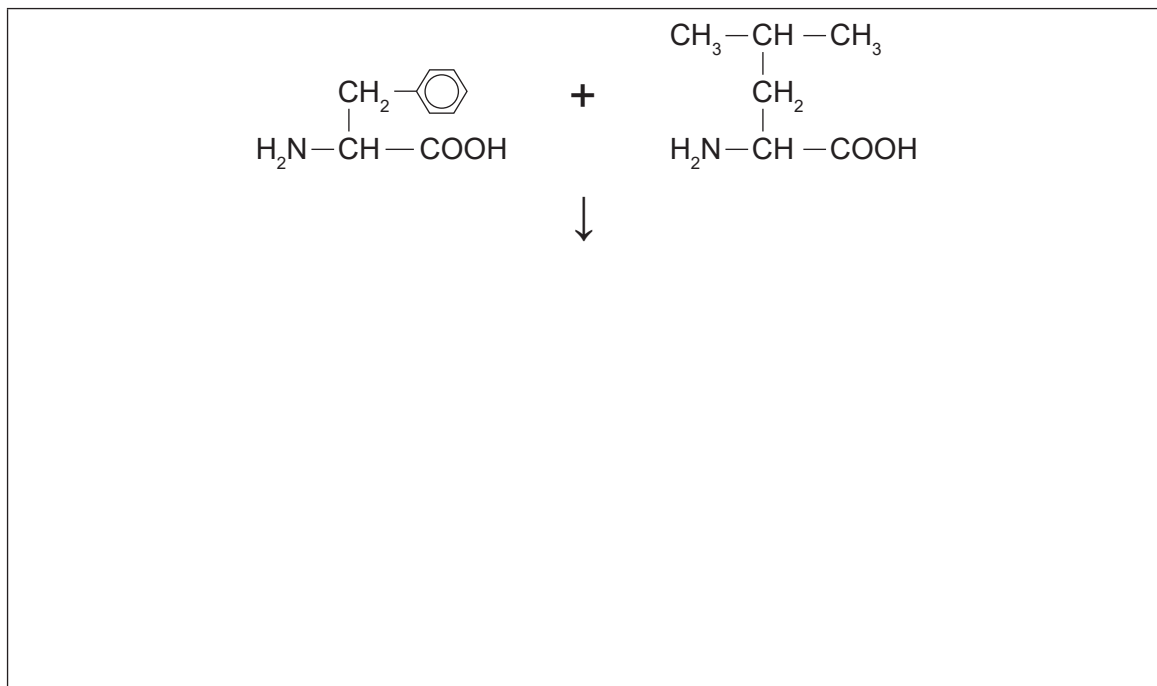

- (f) The biochemist decided to examine how the structure of leucine changes with solution pH. Complete the following table by drawing the structural formula of leucine at the indicated pH. (2 marks)

Structural formula of leucine	pH
	acidic
	alkaline

Question 36

(16 marks)

A student was asked to build a functioning galvanic cell, having been provided with all of the required hardware plus the following substances:

- a piece of magnesium measuring 1 mm by 2 cm by 6 cm
- a piece of copper measuring 1 mm by 2 cm by 6 cm
- a 6 cm long graphite (carbon) rod with a diameter of 1 cm
- 1.0 mol L⁻¹ sodium carbonate solution
- 1.0 mol L⁻¹ magnesium sulfate solution
- 1.0 mol L⁻¹ copper(II) sulfate solution.

There was no requirement for the student to use all of these substances.

- (a) A partially-labelled diagram of the galvanic cell built by the student is shown below. What substances should the student have used in the parts labelled (i) to (iv) to build a functioning galvanic cell? Write the names of these substances in the boxes provided. (4 marks)

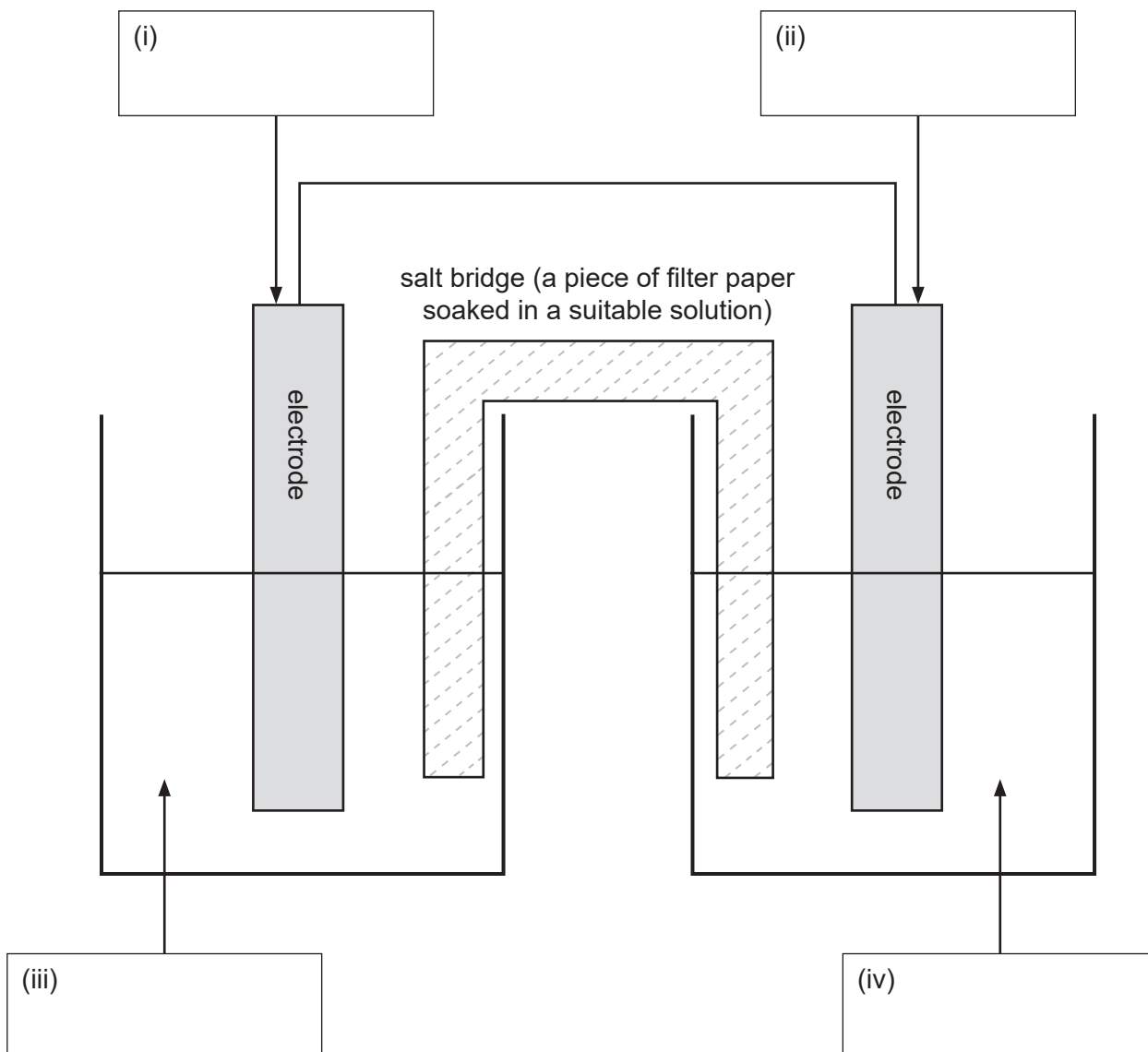

See next page

- (b) Add arrows to the diagram in part (a) to show the direction of movement of electrons through the external circuit. (1 mark)
- (c) Write the half-equations for the reactions occurring at the anode and the cathode in the student's galvanic cell. (4 marks)

Anode half-equation	
Cathode half-equation	

- (d) Calculate the electrical potential difference of the student's galvanic cell. Assume standard conditions. Include appropriate units in your answer. (2 marks)

- (e) Galvanic cells, such as the one shown in the diagram, need a salt bridge.
- (i) State why galvanic cells need a salt bridge. (1 mark)

- (ii) Describe, with reference to ion movement, how the salt bridge in a galvanic cell works. Also state why ion movement occurs as you have described. (4 marks)

See next page

Question 37

(17 marks)

A student standardised an approximately 0.1 mol L^{-1} sodium hydroxide solution with a standard $0.0958 \text{ mol L}^{-1}$ hydrochloric acid solution. The student pipetted 20.00 mL of the sodium hydroxide solution into a conical flask, added 2 drops of indicator and titrated to the end point with the hydrochloric acid. Five titrations were performed.

- (a) Below is a table of the student's results. Determine the average titre. (1 mark)

Titration number	Burette readings (mL)		
	Initial	Final	Titre
Rough	1.35	22.45	21.10
1	21.45	41.50	20.05
2	3.50	23.65	20.15
3	23.65	43.05	19.40
4	2.75	22.85	20.10
Average titre			

- (b) Show that the concentration of the sodium hydroxide solution is $0.0963 \text{ mol L}^{-1}$, correct to three significant figures. (3 marks)

DO NOT WRITE IN THIS AREA AS IT WILL BE CUT OFF

The student used the standardised sodium hydroxide solution to determine the percentage by mass of phosphoric acid (H_3PO_4) in a commercial brand of rust remover.

The student weighed a sample of the rust remover into a small beaker and then transferred it to a 250.0 mL volumetric flask. The beaker was rinsed several times with distilled water and each time the wash water was added to the volumetric flask. The volumetric flask was then made up to the mark with more distilled water. The student titrated 10.00 mL aliquots of the diluted rust remover with the standardised sodium hydroxide solution.

The student's results were as follows:

- mass of undiluted rust remover = 10.05 g
- average titre of standardised sodium hydroxide solution = 24.45 mL.

- (c) Calculate the percentage, by mass, of phosphoric acid in the original, undiluted rust remover. Express your answer to the appropriate number of significant figures. Assume that the rust remover contains no other substances that react with sodium hydroxide.

(8 marks)

DO NOT WRITE IN THIS AREA AS IT WILL BE CUT OFF

Question 37 (continued)

The following table provides some information about three different acid-base indicators.

Indicator	pH range	Acid colour	Base colour
methyl orange	3.2 – 4.4	red	yellow
bromothymol blue	6.0 – 7.6	yellow	blue
phenolphthalein	8.3 – 10.0	colourless	pink

- (d) Which of these indicators should the student use when titrating phosphoric acid with sodium hydroxide? Justify your choice with the aid of a relevant balanced chemical equation. (5 marks)

Question 38**(16 marks)**

Skunks are animals that are perhaps best known for the pungent odour they produce. Several organic compounds are responsible for this odour. One of these compounds contains carbon, hydrogen, sulfur and oxygen.

Combustion of a 5.00 g sample of this compound produced 6.46 g of carbon dioxide and 2.68 g of water. There was also enough sulfur (as sulfur dioxide) to make 10 L of 0.00371 mol L⁻¹ sulfuric acid.

- (a) Determine the empirical formula of the compound. (12 marks)

See next page

Question 38 (continued)

When another 5.00 g sample was vaporised it was found to occupy a total volume of 637 mL at 150 kPa and 40 °C.

- (b) Determine the molecular formula of the compound. (4 marks)

DO NOT WRITE IN THIS AREA AS IT WILL BE CUT OFF

Question 39

(12 marks)

Fluorescent lights are glass tubes which are coated on the inside with rare earth metal phosphates (such as cerium, lanthanum and terbium phosphates) that provide light. Cerium, lanthanum and terbium are expensive, so are recovered once the fluorescent light is no longer functional.

The key steps in one method proposed for recovery of these rare earth metals are summarised below:

- **Step 1:** Physical separation of the rare earth metal phosphates from the glass and any metallic components. This gives an impure powder consisting of cerium, lanthanum and terbium phosphates.
- **Step 2:** Add excess solid sodium carbonate to the powder and heat, completely converting each rare earth metal phosphate to its corresponding oxide, as shown by the following balanced equations:

$$2 \text{LaPO}_4(\text{s}) + 3 \text{Na}_2\text{CO}_3(\text{s}) \rightarrow \text{La}_2\text{O}_3(\text{s}) + 2 \text{Na}_3\text{PO}_4(\text{s}) + 3 \text{CO}_2(\text{g})$$

$$4 \text{CePO}_4(\text{s}) + 6 \text{Na}_2\text{CO}_3(\text{s}) + \text{O}_2(\text{g}) \rightarrow 4 \text{CeO}_2(\text{s}) + 4 \text{Na}_3\text{PO}_4(\text{s}) + 6 \text{CO}_2(\text{g})$$

$$2 \text{TbPO}_4(\text{s}) + 3 \text{Na}_2\text{CO}_3(\text{s}) \rightarrow \text{Tb}_2\text{O}_3(\text{s}) + 2 \text{Na}_3\text{PO}_4(\text{s}) + 3 \text{CO}_2(\text{g})$$
- **Step 3:** Wash the product from Step 2 with water.
- **Step 4:** Add hydrochloric acid to the washed product from Step 3 to leach (dissolve) only the rare earth metal oxides.
- **Step 5:** Use solvent extraction to separate the different rare earth metals from each other and create separate solutions of each of them.
- **Step 6:** Add oxalic acid to the separated solutions to precipitate the rare earth metal ions as oxalate salts.
- **Step 7:** Heat the oxalate salts to recover the rare earth metals as pure oxides, namely La_2O_3 , Tb_4O_7 and CeO_2 .

A chemist used the above procedure to determine the percentage by mass of lanthanum, terbium and cerium in some fluorescent lights and, after completing Step 1, had recovered 1.20 kg of the coating chemicals.

- (a) At the completion of Step 2, the mass of the mixture had decreased by 11.3 g. Calculate the mass of sodium carbonate that reacted with the rare earth metal phosphates. (3 marks)

See next page

Question 39 (continued)

The mass of the solid sent from Step 3 to Step 4 was 1.16 kg. This solid was leached with 6.00 mol L⁻¹ HCl at a solid to liquid ratio of 150 g per litre. Analysis of the solution at the end of leaching showed that it contained lanthanum, terbium and cerium, with its lanthanum concentration being 8.65 x 10⁻³ mol L⁻¹.

- (b) Calculate the percentage, by mass, of lanthanum in the fluorescent light coating chemical, given that the leaching efficiency for lanthanum was 86%.

Note that the balanced equation for the leaching of lanthanum with hydrochloric acid is:

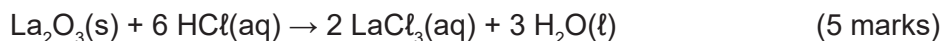

Analysis of the cerium-containing solution produced in Step 5 showed that its cerium concentration was 0.146 mol L⁻¹. This solution, which had a volume of 424 mL, was added to 110 mL of aqueous 1.15 mol L⁻¹ oxalic acid during Step 6, resulting in the precipitation of cerium oxalate, Ce(C₂O₄)₂. The balanced equation for this reaction is:

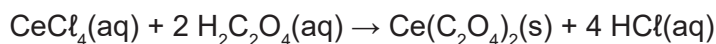

- (c) Did the chemist add enough oxalic acid solution to precipitate all of the cerium? Use calculations to support your answer. (4 marks)

See next page

Question 40

(16 marks)

Thousands of fast-food outlets across Australia use vegetable oil in cooking. Large volumes of vegetable oil waste are thus produced and need to be disposed of. A disposal option is turning the vegetable oil waste into biodiesel.

Vegetable oil waste is a mixture of free fatty acids and triglycerides. Triolein, the triglyceride of the free fatty acid oleic acid, is typically present in large amounts. The condensed structural formulae of oleic acid and triolein are shown below.

$\text{CH}_3(\text{CH}_2)_7\text{CH}=\text{CH}(\text{CH}_2)_7\text{COOH}$ <p>oleic acid (a free fatty acid)</p>	$\begin{array}{c} \text{O} \\ \\ \text{CH}_2\text{O}-\text{C}-\text{C}_{17}\text{H}_{33} \\ \\ \text{CHO}-\text{C}-\text{C}_{17}\text{H}_{33} \\ \\ \text{CH}_2\text{O}-\text{C}-\text{C}_{17}\text{H}_{33} \end{array}$ <p>triolein (the triglyceride of oleic acid)</p>
---	--

- (a) Write a balanced equation, using condensed structural formulae, to show the formation of biodiesel from triolein and ethanol. Assume that a suitable catalyst is present. (3 marks)



- (b) Lipase is a protein that can be used to catalyse the reaction between triolein and ethanol. To which class of biological chemicals (other than proteins) does lipase belong? (1 mark)
-

Question 40 (continued)

The free fatty acids found in vegetable oil waste will react with the ethanol that was intended for biodiesel synthesis, establishing an equilibrium.

- (c) Complete the following equation to show the equilibrium that is established between oleic acid and ethanol. Represent all organic substances as condensed structural formulae and assume acidic conditions. (2 marks)

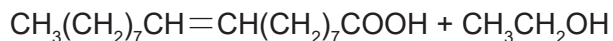

In an industrial setting, reaction conditions are adjusted to favour the forward direction of the oleic acid/ethanol equilibrium.

- (d) Identify **two** different actions that can be carried out to favour the forward direction of this equilibrium. (2 marks)

One: _____

Two: _____

The base sodium hydroxide can also catalyse the reaction between triolein and ethanol. The free fatty acids in the vegetable oil waste also react with the base.

- (e) (i) Write a balanced equation showing the reaction of oleic acid with sodium hydroxide. Represent all organic substances as condensed structural formulae. (2 marks)

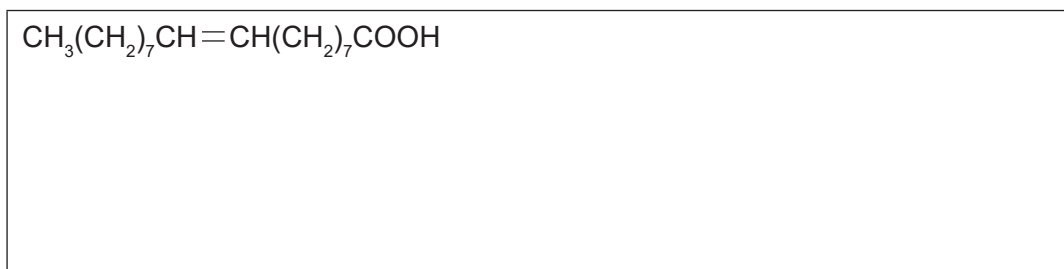
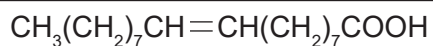

- (ii) To which class of compounds does the organic product of this reaction belong? (1 mark)

See next page

- (f) Which of the catalysts, lipase or sodium hydroxide, is more likely to be the industrially preferred catalyst when using vegetable oil waste to make biodiesel? Justify your answer. (3 marks)

- (g) Other than the recycling of vegetable oil waste, give **two** different reasons why the production of biodiesel from vegetable oil waste is an example of green chemistry but the production of diesel from fossil fuels is not. Each of your reasons needs to contrast biodiesel and fossil fuel diesel. (2 marks)

One: _____

Two: _____

ACKNOWLEDGEMENTS

Question 34

Boerner, L. K. (2019, June). Industrial ammonia production emits more CO₂ than any other chemical-making reaction. Chemists want to change that. *Chemistry and engineering news*, 91 (24). Retrieved April, 2020, from <https://cen.acs.org/environment/green-chemistry/Industrial-ammonia-production-emits-CO2/97/i24>

This document – apart from any third party copyright material contained in it – may be freely copied, or communicated on an intranet, for non-commercial purposes in educational institutions, provided that it is not changed and that the School Curriculum and Standards Authority is acknowledged as the copyright owner, and that the Authority's moral rights are not infringed.

Copying or communication for any other purpose can be done only within the terms of the *Copyright Act 1968* or with prior written permission of the School Curriculum and Standards Authority. Copying or communication of any third party copyright material can be done only within the terms of the *Copyright Act 1968* or with permission of the copyright owners.

Any content in this document that has been derived from the Australian Curriculum may be used under the terms of the Creative Commons [Attribution 4.0 International \(CC BY\)](https://creativecommons.org/licenses/by/4.0/) licence.

An *Acknowledgements variation* document is available on the Authority website.

Published by the School Curriculum and Standards Authority of Western Australia
303 Sevenoaks Street
CANNINGTON WA 6107